

## Corredoras Elevadoras GU 934 (Madeira / PVC / Alumínio)



### Descrição do Produto

As ferragens Corredoras Elevadoras baseiam-se num princípio com 50 anos de experiência. Assim sendo, em zonas onde seja necessário grandes envidraçados e pesos elevados, esta ferragem é a melhor solução, pois todos os movimentos executados pelas folhas são comandados através da manete.

### Campo de aplicação:

GU 934 Largura de folha 720 - 3300  
 GU 937 Largura de folha 600 - 2200  
 GU 934 Folhas até 250 kg ( 400 kg sob consulta )  
 GU 937 Folhas até 150 kg  
 GU 939 Folhas até 90 kg

Desenho Tipo - PVC - 0.44214  
 - Madeira - 0.44271  
 - Alumínio - 0.44347

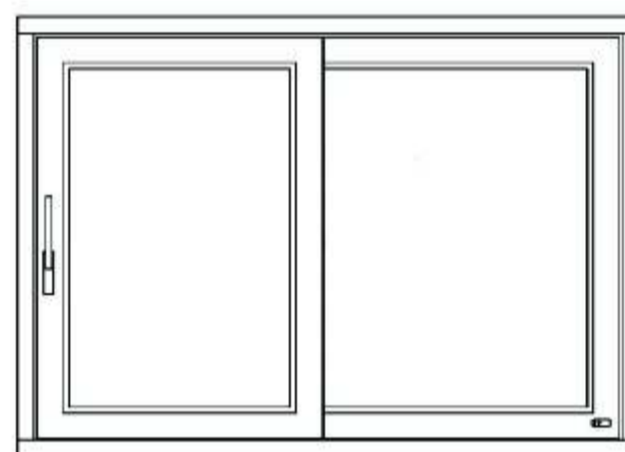

Esquema A - Esquerdo

### Disposição das folhas para os esquemas A até L em G.U-934 e G.U-937

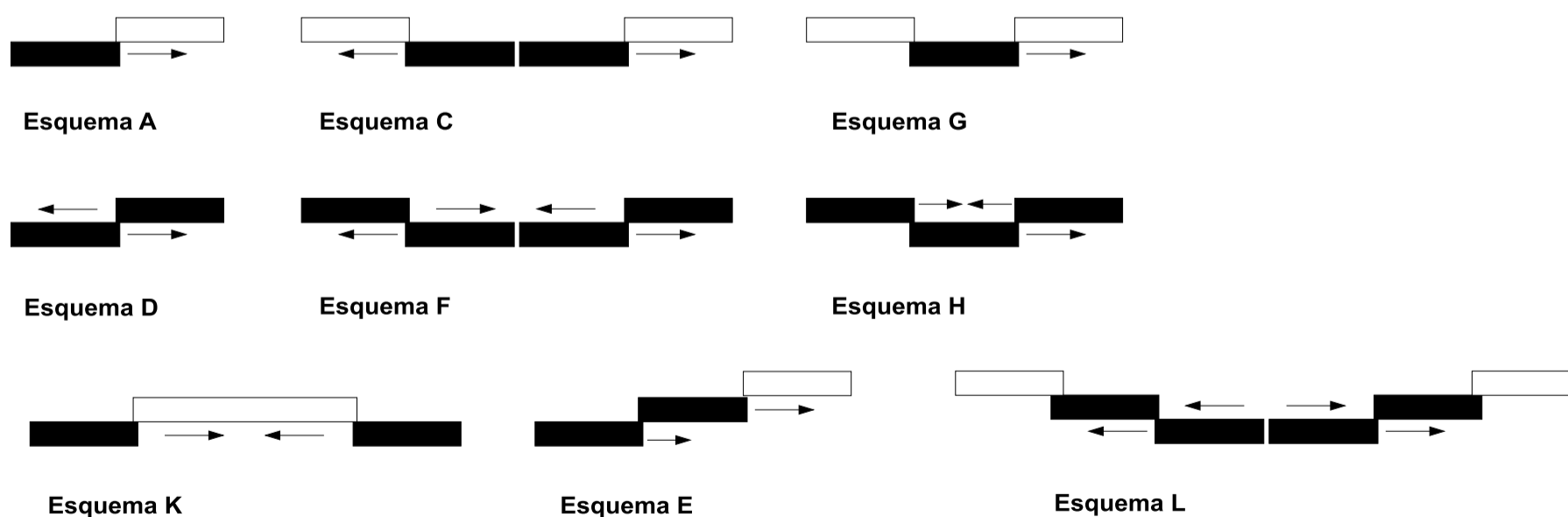

 Folha móvel  
 Folha fixa

**Corredoras Elevadoras GU 934 (Madeira)**

Elem. de fecho

Cremona elevadora

Elem. de fecho

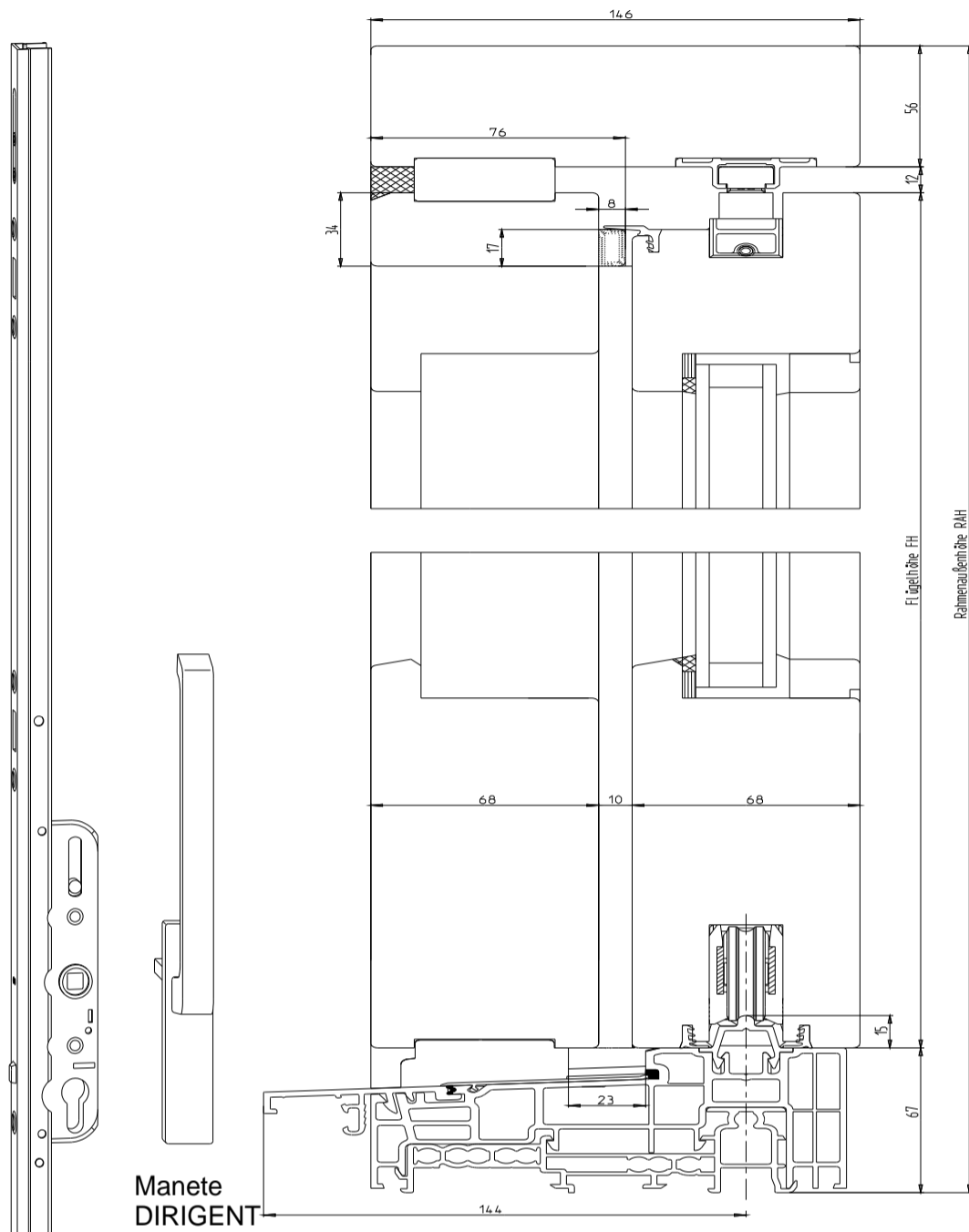

Corte Vertical

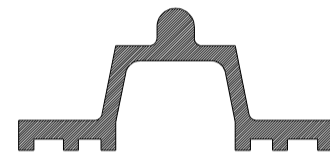

P 432

Perfil opcional para embutir na pedra.

Desenho tipo - GB.38822

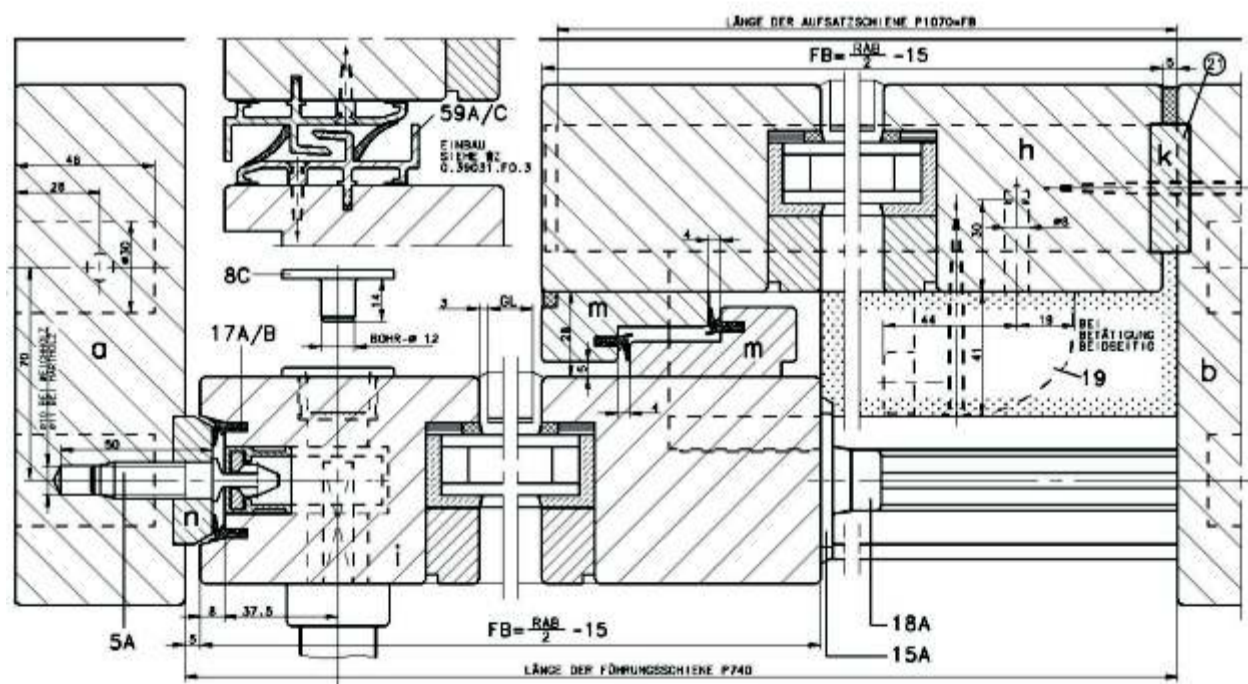

Corte Horizontal

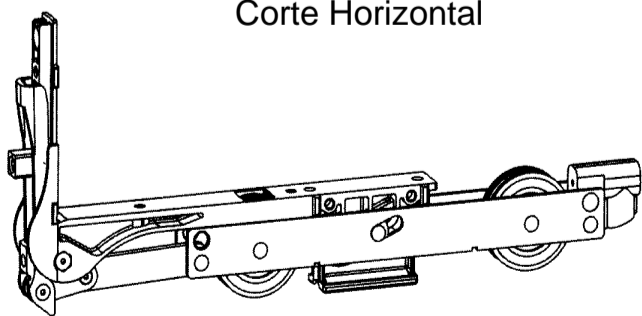

Carro dianteiro



Barra de conexão

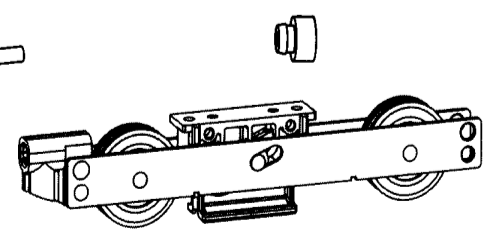

Carro traseiro

**Corredoras Elevadoras GU 934 (PVC)**



Elem. de fecho

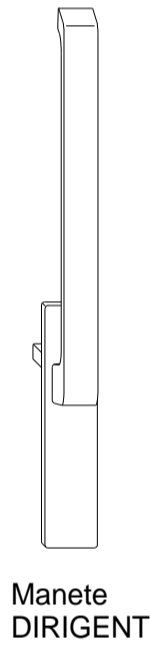

Manete DIRIGENT

Cremona elevadora

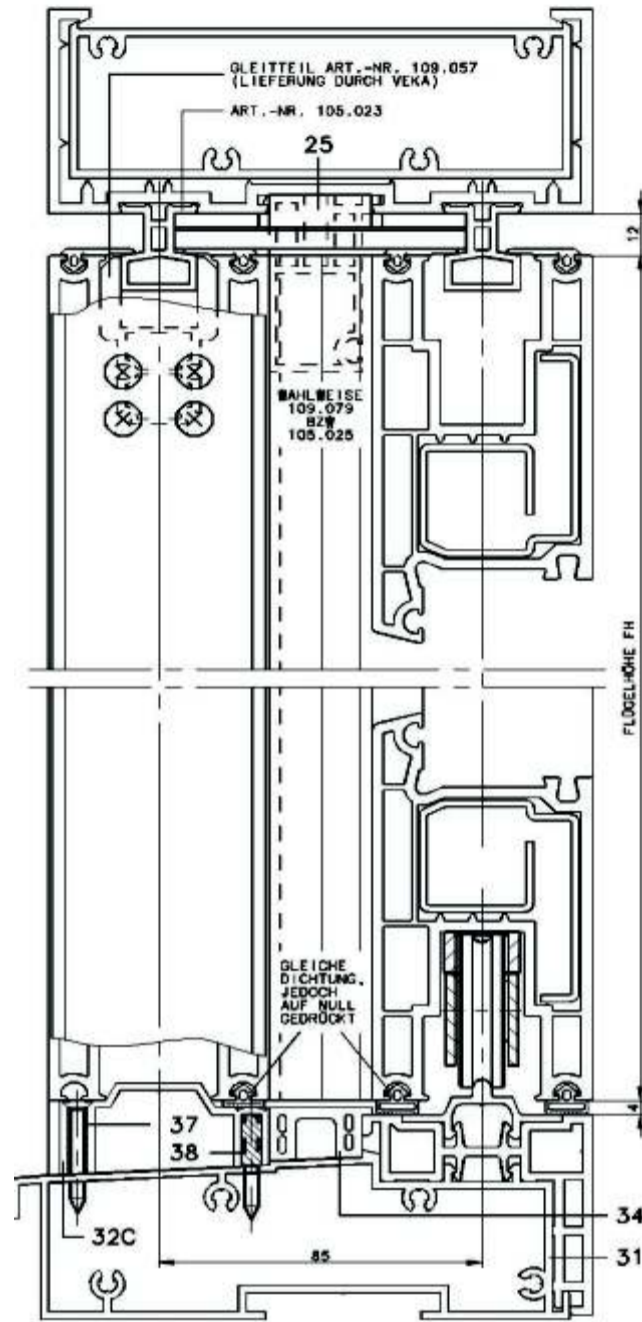
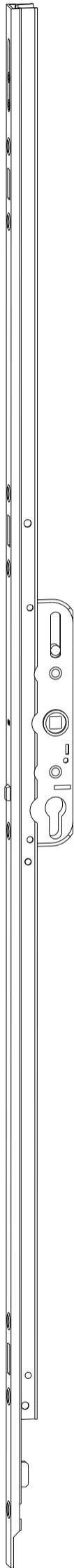

Corte Vertical

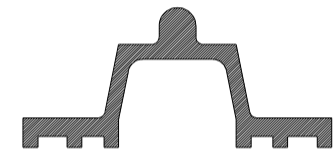

P 432  
Perfil opcional para embutir na pedra  
Desenho tipo - GB.38822

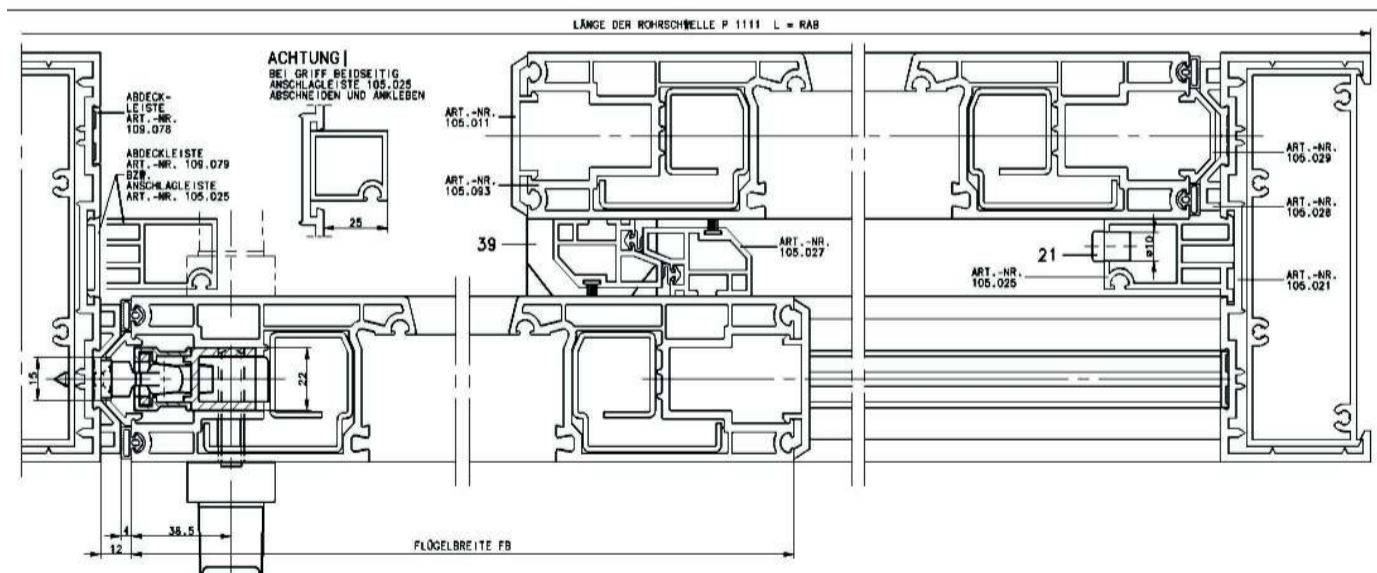

Corte Horizontal



Elem. de fecho

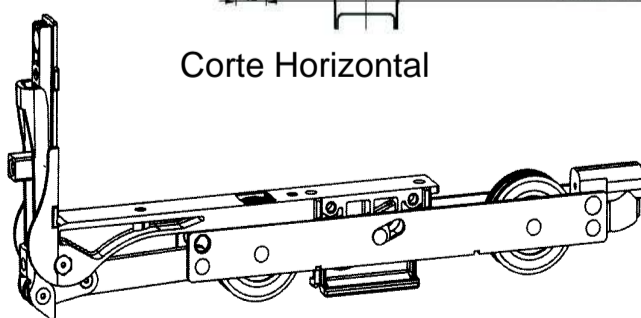

Carro dianteiro

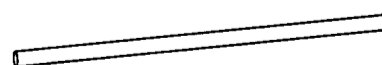

Barra de conexão

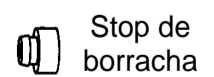

Stop de borracha

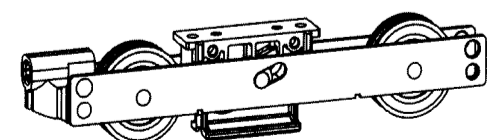

Carro traseiro